

UIL ONE-ACT PLAY BIDISTRICT CONTEST CONFERENCE 6A, AREA 1, BIDISTRICT B, DISTRICTS 27 & 28

CONTEST MANAGER

Carla Schumann
Email: Carla.schumann1@gmail.com
Cell phone: 2107237936

HOST

Debbie Adkinson/Julia A. Morales
dadkison@scuc.txed.net
jamorales@scuc.txed.net

CONTEST DATE

District: March 26, 2024

LOCATION

Samuel Clemens High School, 1001 Elbel Rd., Schertz, TX 78154

ADJUDICATORS

Bi-District Panel:

Melissa Utley

Address:
2911 Ellis Park,
San Antonio, TX, 78259

Phillip Taylor

Address:
1305 Webberville Road,
Austin, TX, 78721

Kelsey Kling

Address:
1011 Oak Meadow Drive,
Dripping Springs, TX, 78620

DIRECTOR'S MEETING WITH JUDGES

The meeting will be in the theatre at 11:15 am on March 26. First show will start at noon.

LOAD IN

Load-in for each school will be thirty minutes PRIOR to your rehearsal.

REHEARSAL & PERFORMANCE SCHEDULE (blind draw was completed by C. Schumann on December 19) A, B, C are determined by play title alphabetically.

District Rehearsal Day - March 25, 2024			District Competition Day - March 26, 2024		
8:45 – 9:45	First Rehearsal	District 27 B	11:15	Director's Meeting	
10:00 – 11:00	Second Rehearsal	District 27 A	12:00	First Play	District 27 B
11:15 – 12:15	Third Rehearsal	District 28 C	1:00	Second Play	District 27 A
12:30 – 1:30	Fourth Rehearsal	District 28 A	2:00	Third Play	District 28 C
1:45 – 2:45	Fifth Rehearsal	District 28 B	3:00	Fourth Play	District 28 A
3:00 – 4:00	Sixth Rehearsal	District 27 C	4:00	Fifth Play	District 28 B
			5:00	Sixth Play	District 27 C

CRITIQUE/AWARDS

Critique will follow after the completion of plays, once adjudicators have submitted their results. After Critiques, awards will follow closely, approximately 7:00 pm.

ELIGIBILITY NOTICE

Eligibility information is all online. Be sure and check that all of your information has been correctly verified. Since the download of student information from the UIL website is in alphabetical order instead of “in order of appearance,” please email a word document of your program information to Carla.schumann1@gmail.com by March 23.

JUDGE’S SCRIPT

Please mail a copy of your cut script to the judges at the address listed above. Please make sure they do not require a signature; are properly marked and mailed to arrive a week or two before the contests. Please label scripts with the contest date and Conference 6A, Area 1, BiDistrict B for judges with multiple contests. You will need to mail scripts prior to knowing if you advanced.. I will notify adjudicators as to who advanced, as I know.

REQUIRED DOCUMENTATION

On the day of the contest, please bring the following:

- Community Standards and Compliance Form signed by Principal or Superintendent
- Proof of Royalty Payment
- State approval for plays not on the approved list
- License to perform and cut from publisher
- Highlighted script with sound cues marked
- Any pertinent permission you have received from the State Office to produce your play including set additions, if any.

UNIT SET

A standard UIL Unit Set including 1 standard door, window and French door will be available for your use.

LIGHT PLOT & STAGE DIMENSIONS

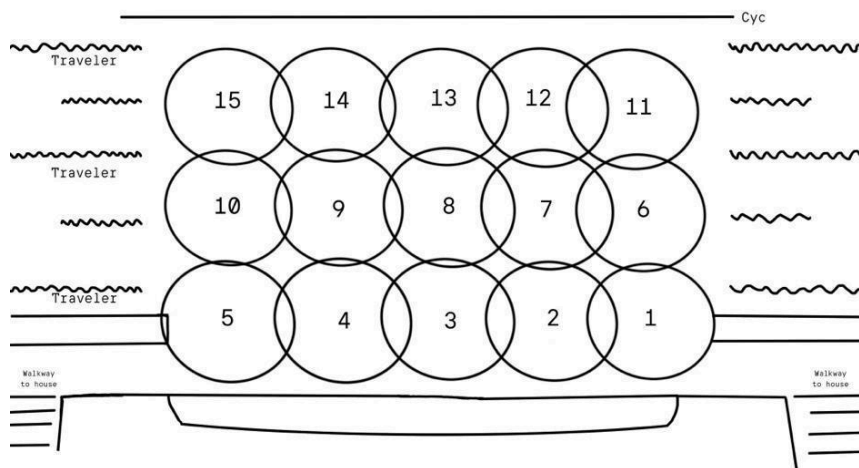

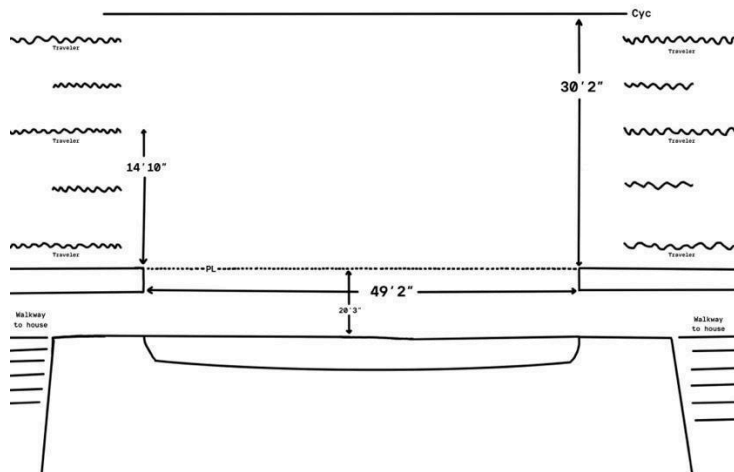

STAGE

Proscenium Opening: 49' 2"

Grand Drape/Curtain Line to:

<u>Apron</u>	20' 3"
<u>Mid Traveler</u>	14' 10"
<u>Cyc</u>	30' 2"

Legs can be pulled on and off stage as needed.

LIGHTING

Light Board - ETC-IONxe 20

15 Lighting Areas (see diagram):

- Row 1 1-5 Areas (Center at Proscenium)
- Row 2 6-10 Areas
- Row 3 11-15 Areas

All area channels can be individually selected (so you can separate downlights, isolate LED area colors, etc.).

Cyc lights: LED RGB

Wash: LED RGB

1 spotlight is available, house left next to the booth.

MISC.

Stage Manager's Panel: Stage Left

Loading dock: Loading is at sidewalk level. Driveway for loading dock is between the band hall and our shop.

Sound: Please bring your own device (laptop or MP3 player). An aux cord will be provided.

Comms: 2 headsets in the booth and one stage left and one stage right backstage.

LIGHT CUES

We recommend that you plan to record light cues during your rehearsal. Here is a link to a [cue sheet](#) to assist you.

SITE INFORMATION**PARKING**

Parking will be very limited. All contest personal vehicles will park along fence behind the stadium. Busses and box trucks will park in the fenced lot directly behind the stadium.

FOOD POLICY

You are welcome to eat and drink in your rooms, but we ask that you please leave the room neat and that you not throw full drinks into the trash cans. We will have a green room full of goodies for the directors. Simple concessions (chips, candy, soda, water) will be available before and after performances. A list of local restaurants will be added to the Google site.

DRESSING ROOMS

Each school will have a space to use during the contest, spaces do not have mirrors, so you will need to bring some with you. There are bathrooms available in the Event Center. We recommend during the day that you do not leave valuable items in the room.

PLAY TITLES:

Please send your titles by email to Carla Schumann by February 23, 2024.